

Installation Guide
Split/Splitless Capillary Inlet
Accessory 19251A

© Agilent Technologies 2000

All Rights Reserved. Reproduction, adaptation, or translation without permission is prohibited, except as allowed under the copyright laws.

Part number 19251-90117

First Edition, DEC 2000

Replaces Part No. 19251-90110 Operating and Service Manual.

HP® is a registered trademark of Hewlett-Packard Co.

Printed in USA

Safety Information

The Agilent Technologies Split/Splitless Capillary Inlet meets the following IEC (International Electrotechnical Commission) classifications: Safety Class 1, Transient Overvoltage Category II, and Pollution Degree 2.

This unit has been designed and tested in accordance with recognized safety standards and designed for use indoors. If the instrument is used in a manner not specified by the manufacturer, the protection provided by the instrument may be impaired. Whenever the safety protection of the Agilent 19251 has been compromised, disconnect the unit from all power sources and secure the unit against unintended operation.

Refer servicing to qualified service personnel. Substituting parts or performing any unauthorized modification to the instrument may result in a safety hazard. Disconnect the AC power cord before removing covers. The customer should not attempt to replace the battery or fuses in this instrument.

Safety Symbols

Warnings in the manual or on the instrument must be observed during all phases of operation, service, and repair of this instrument. Failure to comply with these precautions violates safety standards of design and the intended use of the instrument. Agilent Technologies assumes no liability for the customer's failure to comply with these requirements.

WARNING

A warning calls attention to a condition or possible situation that could cause injury to the user.

CAUTION

A caution calls attention to a condition or possible situation that could damage or destroy the product or the user's work.

Sound Emission Certification for Federal Republic of Germany

Sound pressure $L_p < 68$ dB(A)

During normal operation

At the operator position

According to ISO 7779 (Type Test)

Schallemission

Schalldruckpegel $LP < 68$ dB(A)

Am Arbeitsplatz

Normaler Betrieb

Nach DIN 45635 T. 19 (Typprüfung)

Installing the Split/Splitless Capillary Inlet Accessory 19251A

WARNING Hydrogen (H₂) is flammable and an explosion hazard when confined in an enclosed space (for example, the oven). In ANY application using H₂, turn off the supply at its source before working on the instrument.

Caution The insulation on the GC is made of refractory ceramic fibers. Ventilate your work area. Wear long sleeves, gloves, safety glasses, and a disposable dust/mist respirator. Dispose of insulation in a sealed plastic bag.

Preparing the Instrument

WARNING Hazardous voltages are present in the instrument whenever the power cord is connected. Avoid a potentially dangerous shock hazard by disconnecting the power cord before working on the instrument.

1. Set the main power line switch to the off position.

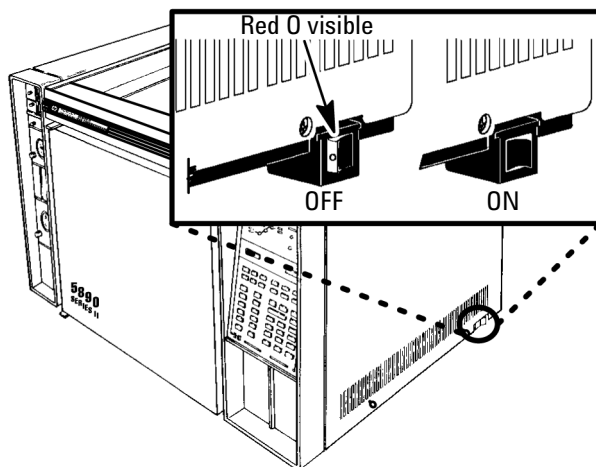

Installing the Split/Splitless Capillary Inlet Accessory 19251A
Preparing the Instrument

2. Disconnect the power cable from its receptacle.
3. Allow time for the oven and heated zones to cool.
4. When the heated zones are cool, turn off all gas supplies at the source.
5. Remove the injection port cover by grasping its back edge and lifting it upward. If an autosampler is installed, the injection port cover will not be present.

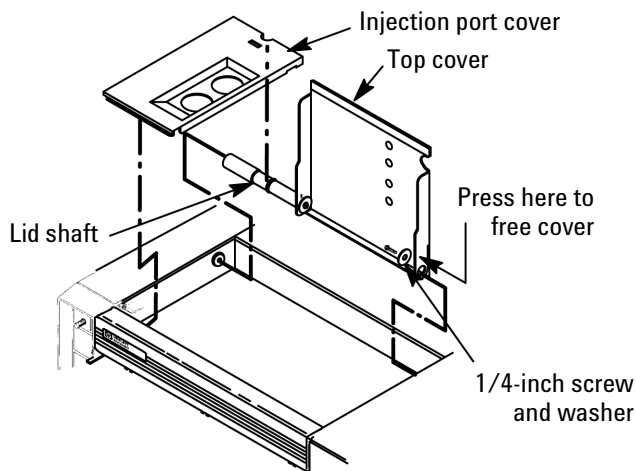

6. If an autosampler is installed on the instrument, it will be necessary to remove it and its mounting bracket to allow removal of the left side cover.
 - a. Remove the autosampler tray from its mounting bracket by simultaneously lifting and turning the two tray locks that hold it in position, then sliding the tray away from the instrument.
 - b. Lift the autosampler tray from its mounting bracket and set it aside.
 - c. Remove the autosampler bracket by removing the six screws securing it to the instrument.

7. Remove the two screws securing the left side panel along its bottom edge.

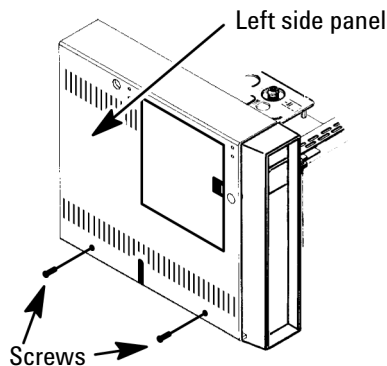

8. Slide the left side panel towards the rear of the instrument and lift.
9. Remove the electronics carrier top cover by grasping it at the rear and lifting upwards until its catch releases, then pull it towards the rear of the instrument.
10. Remove the right side panel by removing four screws, two each along its top and bottom edges.

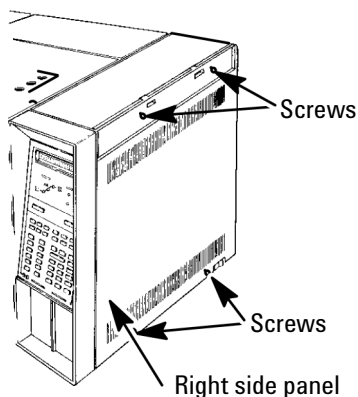

Installing the Split/Splitless Capillary Inlet Accessory 19251A
Preparing the Instrument

11. Remove the back cover of the instrument by removing four screws and sliding the cover off the rear of the instrument.

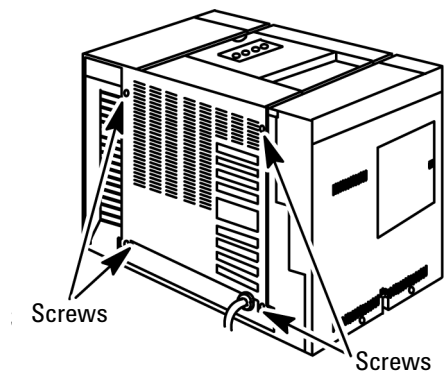

Installing the Inlet

Caution

The insulation on the GC is made of refractory ceramic fibers (RCF). Ventilate your work area. Wear long sleeves, gloves, safety glasses, and a disposable dust/mist respirator. Dispose of insulation in a sealed plastic bag.

1. If present, remove the cover plate from the inlet mounting location. Remove enough insulation to allow the injection port to fit.

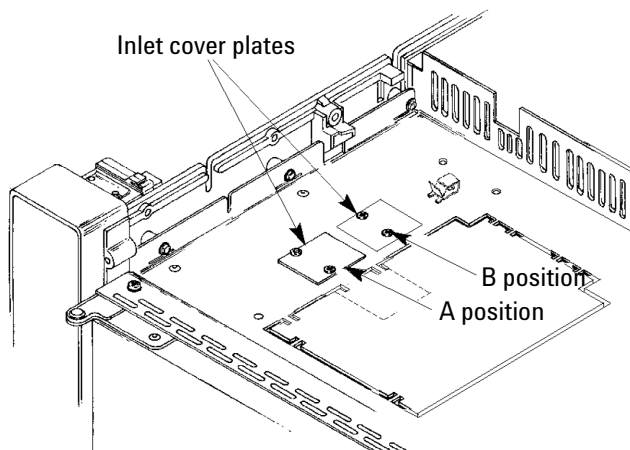

2. Plug the opening at the inlet bottom to prevent contamination.

Installing the Split/Splitless Capillary Inlet Accessory 19251A
Installing the Inlet

3. Install the inlet from the top of the oven. Secure the inlet with two M4 screws.

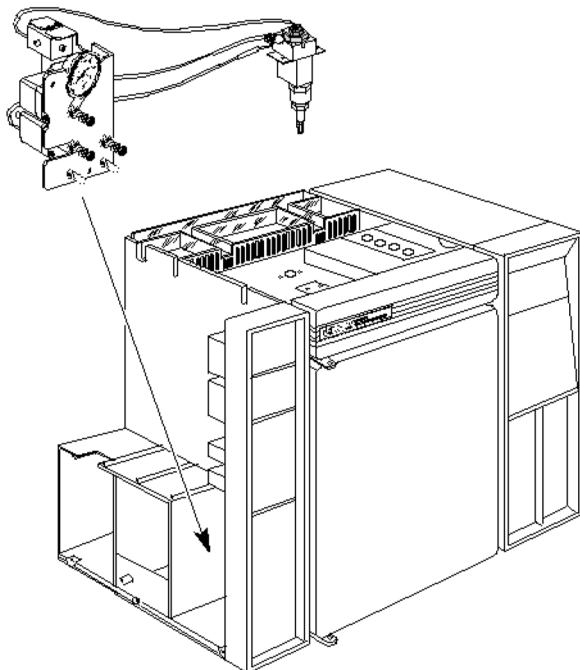

4. Remove the flow-control label plate in the injection port A or B location. The plate is glued in place and is removed by pushing it firmly through openings in the back of the flow panel to get it started, then pull it free.
5. Place the provided self-adhesive split/splitless flow plate in the space where flow-control components for the inlet are to be installed.

Caution

Avoid sharp bends in the tubing. A tight bend radius may crimp the tubing.

6. There are two threaded studs on the back of the main flow panel for installing the inlet flow module. Place the flow module assembly on the

studs, securing it with a M4 hex nut on each stud. Use a 7-mm nut driver to tighten the nuts.

Split/Splitless Capillary Flow module

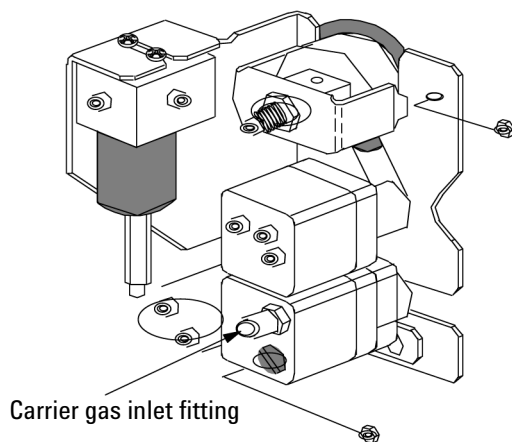

WARNING

Hydrogen (H₂) is flammable and an explosion hazard when confined in an enclosed space (for example, the oven). In ANY application using H₂, turn off the supply at its source before working on the instrument.

7. Using 1/8-inch OD copper tubing, connect the carrier gas supply tube to the carrier gas inlet fitting.
8. Route the heater and sensor leads through the instrument rear plastic tray to the main circuit board. Heater and sensor wires must be connected to matching heated zones (INJ A sensor on P7 and INJ A heater on J9 or INJ B sensor on P7 and INJ B heater on J9). Connect the heater and sensor leads to the instrument main circuit board as follows:

Installing the Split/Splitless Capillary Inlet Accessory 19251A
Installing the Inlet

- Agilent 4890 Series and 5890 SERIES II:** Connect the sensor leads (white) to P7. Connect the heater leads (red) to J9. Connect the purge valve leads (orange, red) to P8 (polarity in this case does not matter).

4890 Series and 5890 SERIES II Main Circuit Board

Position 7 & 8 = Inj A position
 Position 9 & 10 = Inj B position
 Position 3 & 4 = Purge A
 Position 5 & 6 = Purge B

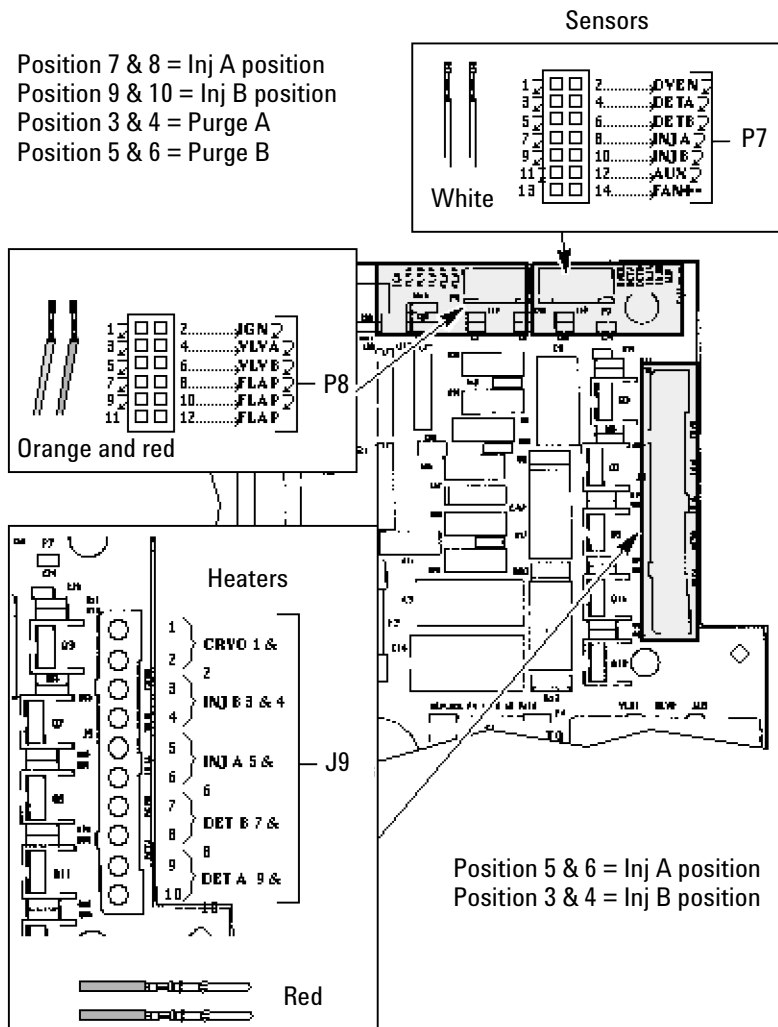

10. **Agilent 5890A:** Connect the sensor leads (white) to J7. Connect the heater leads (red) to J9. Connect the purge valve leads (orange, red) to J8 (polarity in this case does not matter).

5890A Main Circuit Board

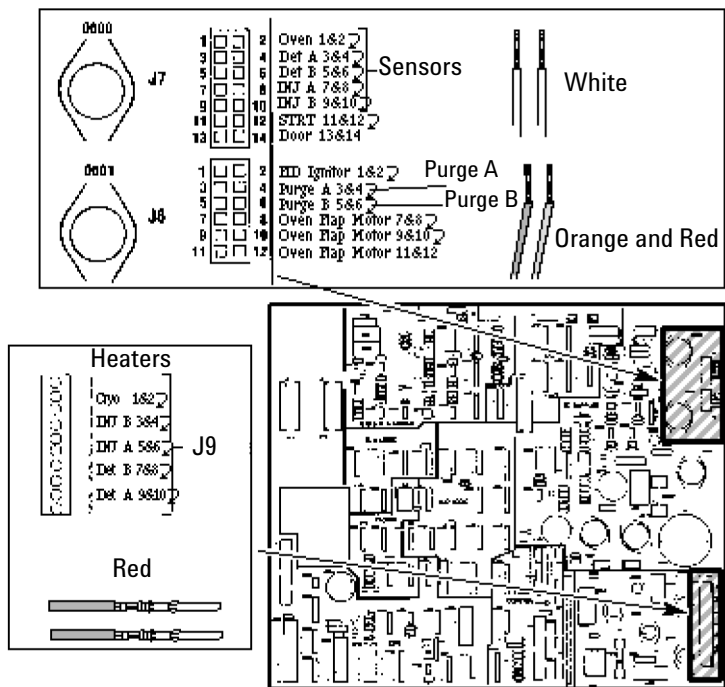

11. Install the lower insulation cup and insulation over the inlet inside the oven. Secure the cup using two M4 screws provided.

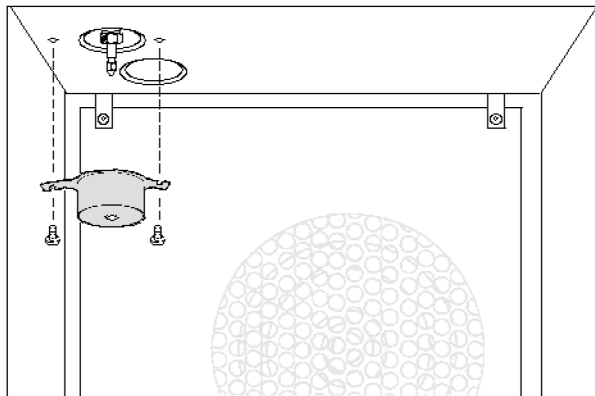

Restore the GC to Operation

For additional information on the steps below, see the *Agilent 4890 GC Operating Manual*.

1. Install the column.
2. Restore carrier gas flow and leak test the new connections.
3. If the system is leak-free, reinstall the panels and covers. Reconnect the instrument power cord and restore power.



Agilent Technologies



Printed on recycled paper.



This product is recyclable.

Agilent Technologies, Inc.

Printed in USA Dec 2000



19251-90117